

Volume 35 Issue 9

December 2004

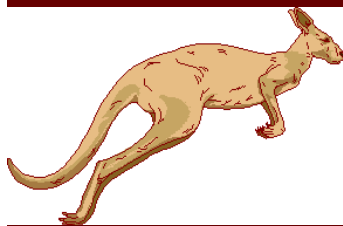

IO CLUB

SUBURBS AMATEUR RAD

WESTERN AND NORTHERN

WANSARC NEWS December 2004

Incorporated Number A7611

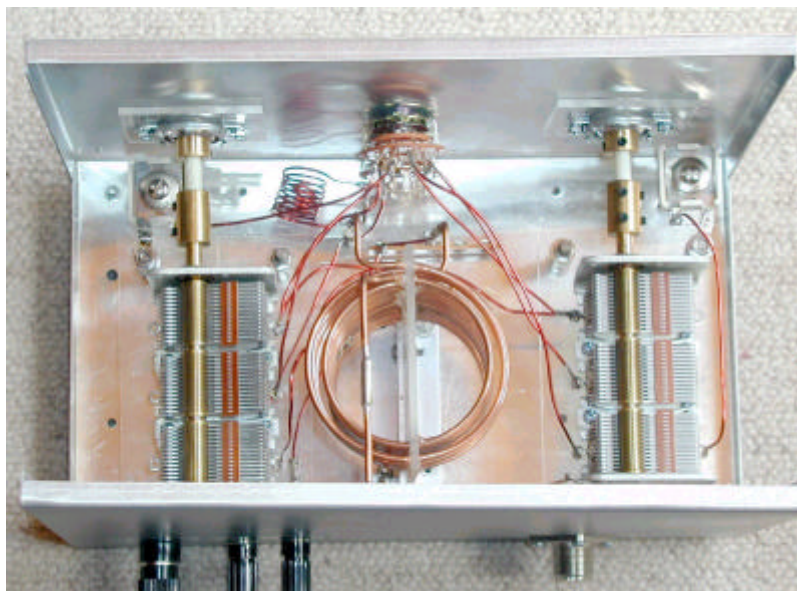

Who said Homebrew is dead? Take a look at this Z-Match for 1.8-30MHz by Peter VK3YSF. Beautiful construction, Peter. Catch Peter on air for more.

DELIVER TO:

If not delivered within 7 days, please return to:
WANSARC PO Box 336 RESERVOIR Victoria 3073

NEXT MEETING Friday 3 December 2004— Final club function for the year. 1900 hours onwards—TINA'S PIZZA PLACE, Plenty Road, PRESTON. Talk in on 146.450. See inside for more.

And that was the year that was	2
Editors final message	3
Final WANSARC meeting 2004	3
Eyeball San Diego style	4
WIA and club liabilities	5
Laughter is a Medicine	6
Low voltage alarm	7

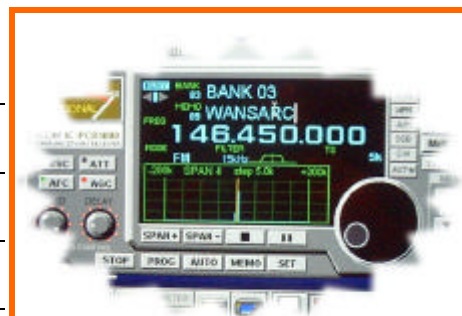

CLUB FREQUENCIES

146.450Mhz FM and
28.470MHz USB

And that was the year that was.....2004



More shots of Peter VK3YSF's new Z-match. Peter has meticulously constructed this beautiful piece of gear and is comfortably running 100 watts. Well done, Peter.

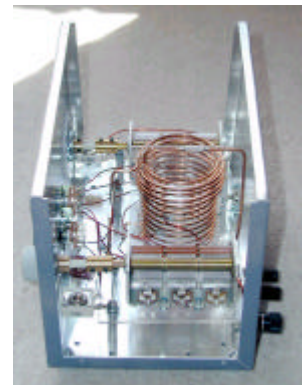

Magazine Editor/Producer Message 2004.



Dear Readers,

It is with a tinge of sadness that I now complete my final club magazine for WANSARC. This has been my fourth stint at producing our magazine since joining the club in the late 70's and I have enjoyed this latest stint of some 3 years. The time spent producing the magazine has been validated by the regular contributions from our members and the many positive comments from our members and other readers. I am sure that this will continue with Mick VK3CH stepping forward to take over the reins. WANSARC has always been a small but strong club and this will continue into 2005 with the contributions of all of our members. To Mick, best of luck with the magazine.....73 DE Mark VK3PI

Final 2004 Club night—December 3, 2004

Yes folks, such was the success of our mid-year pizza night at TINA's in Plenty Road, PRESTON, that the club committee and members have agreed to hold our final meeting night at this establishment.



So put this in your diary—TINA's PIZZA PLACE, Plenty Road, Preston between MURRAY ROAD and PENDER STREET, PRESTON.

It is on the western side of Plenty Road and if you are heading north and cross WOOD Street, you have gone too far. If you are heading south on Plenty Road and cross MURRAY Road, you have gone too far!!!

Talk in will be conducted on the club frequency of 146.450MHz and rest assured if your heart (and stomach) do not desire Pizza, other feasts may be obtained from the menu.

This will be our final get together for 2004 so please make the effort and come and meet other club members. We intend to fill the whole place again.

Reminder: DECEMBER 3, 2004 anytime after 1900 hours, TINA's, Plenty Road, Preston, western side of Plenty Road between MURRAY ROAD and PENDER STREET.

Save me a seat, PLEASE!!!

The WANSARC club net via VK3RTL-R, VK3HFS-L, VK3NE-L and on occasions ZL1VK-R Auckland . With many listeners and links, the WANSARC net is unique.

Call in 1930 hours local time via 146.450MHz FM simplex, or via echolink.....

WANSARC—ham radio word for FUN!!!



The band may be open and you're sitting on the frequency listening????!! Get on and give a holler—you may be surprised as to the response.

GRAND EYEBALL 11, Lake Morena, San Diego, California by Chris VK3FY

I arrived in LAX after a 22 hour journey that began in Melbourne via Brisbane then to Auckland and finally to L Angeles.

It was a good feeling that Kellogg KA2LOG had arranged for Eddy KG6BBQ to pick me up at LAX. I certainly would not have been in a fit state to drive as I was tired after my journey across the pacific. If you are wonderi why so long a haul, will its easy it was the only flights available.

Eddy was a good host and we waited for another ham to arrive from Vancouver before we finally departed LA heading south for our eventual destination LAKE MORENA.

Lake Morena was the site chosen for the Grand Eyeball 11. This is a gathering of radio amateurs usually of F pino decent, but it has grown now to be bigger than just that. I was not expecting the turnout that was to unfold as we finally arrived at the camp site.

There was well over 400 hams and there families from all over the US and Canada. Plus some eager partici pants from Philipines, Japan and yes Australia. For the first time 5 countries were participating.

I had a great time catching up with mates I had got to know not just on the airways but also over Echolink.

I am looking forward to the next big one which will be held outside of North America for the first time. In the pa rade of BORACAY, and I will be there as this is one of those types of Hamfests that just need to be attended. not a Dayton and never was intended to be, but its a gathering of mates and there families which now has gro over 11 years and now is transcending borders which is what ham radio is all about.

See you in BORACAY Grand Eyeball 12 May 2005.

Regards

Chris de VK3FY



From left to right K6NGY, W6XD, VK3FY, JA1UZQ and N6WIN



Chris VK3FY is certainly aiming to be on Baracay Is land for the 12th 2005 Grand Eyeball—say, where the heck is this island anyway?? Perhaps other club members may wish to tag along for the DX and fiiendship!!

WIA announces attractive club liability insurance deal

WIA President, Michael Owen, VK3KI, announced at the last WIA South Australian and Northern Territory Division meeting and dinner on 26 November 2004 that the WIA had been successful in obtaining liability insurance to cover the WIA and available for its Affiliated Clubs.

Michael stressed that it was fundamentally important that the liability cover really met the needs of the clubs and provided adequate cover. The insurer was QBE Insurance (Australia) Limited and Mercantile Mutual Insurance (Australia) Limited, very respected and very substantial insurers.

An important feature was that it was completely clear that not only the club, its officers and employees were covered, but also each member of the club was also covered while engaged in club activities. Indeed, volunteers who are not members of a club but helping at a club function were also covered. The liability of a member to another member was also covered, unlike many similar policies.

The cover was \$10 million, though that sum could, if it was essential, be increased.

The premium was also attractive. There was a base premium of between from about \$122 to about \$134, depending on the state, as stamp duty varied from state to state. Then, a sum per club member of between from about \$1.22 to \$1.31, again depending on the state, was added.

But, what was important and exciting was that the premium per member was not required for any member of a club who was already a WIA member, either as a Full Member or a Provisional Member.

Michael said that the attractive terms were secured because the WIA was accepting responsibility for much of the administration of the scheme, and there was a single policy, both factors reducing the insurers and brokers administration costs. The policies would commence on 1 February next year, and the WIA would be soon writing to every club, inviting them to complete a form applying for Affiliation, based on the criteria that had been announced last week, necessary for the liability insurance for Affiliated Clubs, and also inviting applications from the clubs to be included in the WIA/Affiliated Clubs liability insurance.

“The WIA hopes that as many clubs as possible will be able to join the scheme by 1 February, and in considering whether to cancel existing cover, it was extremely important that the clubs consider whether the policy offered by the WIA provided better cover, as well as looking at the cost. Only the clubs could do that, as the WIA did not know their existing cover, nor was it qualified to make such a judgement,” said Michael.

He stressed that the WIA was doing this as a service to clubs, acknowledging the serious concern of so many clubs and the promises the WIA had made to the clubs. He said that the WIA did not receive any commission or other benefit for insurance cover taken by the clubs.



LOOKING FOR A USED CAR.....??

It is refreshing to go to a used car lot and find all of the cars look as if they are in great nick!!!

Now they say that a picture is worth a 1000 words, and Geoff VK3KAS looks as if he is having a bit of trouble working out which car to take for a test spin.

In any case the man and the machine both look very dapper—pic snapped at Dawson Street Victoria Police Transport Branch.



Laughter is a medicine.....

- Last week I stated this woman was the ugliest woman I had ever seen. I have since been visited by her sister and now wish to withdraw that statement. ~Mark Twain
- The secret of a good sermon is to have a good beginning and a good ending; and have the two as close together as possible.~George Burns
- Santa Claus has the right idea ... visit people only once a year. ~Victor Borge
- Be careful about reading health books. You may die of a misprint. ~Mark Twain
- What would men be without women? Scarce, sir .. mighty scarce. ~Mark Twain.
- By all means marry. If you get a good wife, you'll become happy; if you get a bad one, you'll become a philosopher. ~Socrates
- I was married by a judge. I should have asked for a jury. ~Groucho Marx
- My wife has a slight impediment in her speech. Every now and then she stops to breathe. ~Jimmy Durante
- I don't feel old. I don't feel anything until noon. Then it's time for my nap. ~Bob Ho.

PHILOSOPHY



One reason why WOMEN live longer than men.....

- A little girl was talking to her teacher about whales. The teacher said it was physically impossible for a whale to swallow a human because even though it was a very large mammal its throat was very small.

The little girl stated that Jonah was swallowed by a whale.

Irritated, the teacher reiterated that a whale could not swallow a human; it was physically impossible.

The little girl said, "When I get to heaven I will ask Jonah".

The teacher asked, " What if Jonah went to hell?"

The little girl replied, "Then you ask him".



Fireground instructions

1. Find flat ground prior to extending stabilising arms.
2. If a vehicle can be found, use it as a stabilizer.
3. If using car for stabilisation, ensure stabiliser arm is firmly planted on the bonnet or boot.
4. Where possible complete fire job well prior to owner of vehicle returning.
5. If owner returns while making up, thank owner profusely for their public service.

STEVE VK3JSR THANKS WANSARC MEMBERS

Recently the WANSARC Committee and club members agreed to make a donation of \$100 to Steve Reining, VK3JSR, to assist with covering costs of repairing the repeater controller for VK3RHF. Steve is the brainchild behind the multi-repeater system—here is Steve's response to members following this donation.

A Very Welcome—thankyou to all at Wansarc for your Donation towards VK3RHF. Progress is slowly but surely moving forward with getting VK3RHF back on air. A number of things are currently on the move forward. The Controller has been safely returned [REPAIRED] from the USA. The UHF Links between the 3 Sites are currently being reconfigured for the new 70cm Band plan. More 80 MHz transceivers are being modified for 29 mhz voting receivers and another 6mtr receiver. More UHF Links are being sort and configured for the extra voting receivers A new cabinet has been purchased for the controller, which needs alot of metal work, cut outs etc for all the DB 9 and 15 connector for all the ports and ancillary inputs and outputs. I purchased a Doug Hall 4 channel voter for 10 metres So the 2 channel voter will be used on 6 mtrs and another 2 channel voter built for 70 cm Both voting receivers will be at Mt Macedon. UHF Linked back to Olinda Once all is built and together it will all need to be aligned and levels matched, especially the voting receivers to vote correctly. Critical audio levels are required for Audio noise quieting comparitor voters.

Please forward my thanks to all for the donation and i will try to keep updating progress as it happens

Steve Reining VK3JSR
VK3RHF system Owner Operator
29.640/29.540 - 53.625/52.625 - 438.750/433.75 - 1273.400/1293.400

CIRCUIT IDEAS—LOW VOLTAGE ALARM

This low voltage circuit can be used to monitor batteries and other volatile sources of current for problems. The circuit sounds an alarm and lights an LED, but can be interfaced to any number of other circuits for many different uses. Schematic

Parts:	
R1, R32	1K 1/4W Resistor
R21	5K Pot
U11	LM339 Op Amp IC
D11	1N5233B Zener Diode
D21	LED
BZ11	Piezo Buzzer
MISC1Board,	wire, socket for IC

Notes:

1. The circuit will operate from 9V to 12V.
2. Adjust R2 until the alarm goes off at the correct voltage.

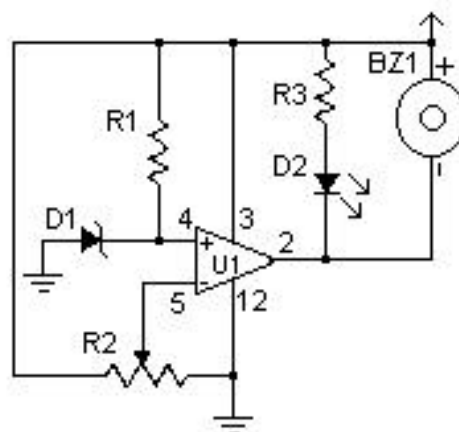

Don't forget—someone could be listening! Ah, have I got your attention. I guess this message means two things—be aware of your behaviour on air as many people could be listening to your transmissions. Some of the things heard on air are just not Amateur Radio.....secondly, don't be afraid to pop up on air, particularly on 10 metres. Remember the club's listening frequency of 28.470MHz USB. Give a call from time to time, particularly weekends. You never know who might be listening from the club or afar.

WANSARC VK3AWS

PRESIDENT: Grant Stowell VK3HFS

Telephone: 0419 007 718

SECRETARY: Mark Stephenson VK3PI

Telephone: 0425 768 320

Email: wansarc@wia.org.au

All correspondence to be addressed to the SECRETARY:

PO Box 336

RESERVOIR 3073



WANSARC CLUB PROFILE

History

The Western and Northern Suburbs Amateur Radio Club (WANSARC) was first formed in 1969 and since then has served the needs and interests of amateur radio operators, short wave listeners and those interested in hobby radio and electronics. The club is not gender specific, having both female and male members. Members come from all walks of life with a mix of experience, young and mature, novice and technical. The most important aspect of the club is the willingness of all members to share their knowledge for the benefit of others. Members mainly reside in the west and north of Melbourne, however membership is encouraged from all interested.

Meetings

From September 2003 Building K, Northern Metropolitan Institute of Technology (NMIT), St. Georges Road, Preston (western side between Bell Street and Cramer Street) Melway 18 E12

Meetings held on the 1st Friday of each month (excluding January) commencing at 7.30pm local time. Talk in on 146.450MHz FM—call club station VK3AWS.

Benefits

Free technology and related presentations, sponsored construction activities, discounted (and sometimes free) equipment, network of like minded radio and electronics enthusiasts, excellent club facilities and environment.

Club Nets

146.450MHz FM each Tuesday evening commencing 7.30pm local time. Linked to Echolink for intrastate, interstate and international stations participation.

More Information

Website: www.wansarc.org.au

Committee: Bob VK3EL, Tony VK3JED, Gordon VK3YOD, Grant VK3HFS, Mark VK3PI
Dan VK3DWH

Email: wansarc@wia.org.au

Secretary: Mark Stephenson VK3PI vk3pi@optusnet.com.au

Postal: WANSARC PO Box 336 RESERVOIR 3073

VK3AWS

A proud tradition of supporting hobby radio and electronics enthusiasts since 1969